



**DIVISION: 03 00 00—CONCRETE**  
**Section: 03 15 00—Concrete Accessories**  
**Section: 03 21 00—Reinforcing Steel**

**REPORT HOLDER:**

CCL

**EVALUATION SUBJECT:**

CCL SHEARTRACK®

**1.0 EVALUATION SCOPE**

**Compliance with the following codes:**

2018 and 2015 *International Building Code*® (IBC)

**Property evaluated:**

Structural

**2.0 USES**

The CCL Sheartrack® assemblies are large-head shear studs that are welded to a steel base rail and used as shear reinforcement in flat concrete slabs in place of reinforcement stirrups, drop panels or column capitals. The CCL Sheartrack® assemblies increase the punching shear resistance of the slabs.

**3.0 DESCRIPTION**

**3.1 General:**

The CCL Sheartrack® assemblies are reinforcement assemblies that are formed by welding large-head shear studs to flat steel base rails. The studs are 3/8-, 1/2-, 5/8- and 3/4-inch-diameter (9.5, 12.7, 15.9 and 19.1 mm) studs as described in the manufacturer's quality manual. The stud dimensions and base rail dimensions are given in Tables 1 and 2, respectively. The CCL Sheartrack® assembly details and dimensional details are shown in Figures 1 and 2.

The CCL Sheartrack® assemblies have been tested and comply with the requirements of ASTM A1044.

**3.2 Materials:**

**3.2.1 Studs:** The studs are produced from ASTM A29 Grade 1010 through 1020 steel and must conform to the following physical and mechanical requirements in accordance with the prescribed values in Table 1 of ASTM A1044:

- Tensile strength, min, psi [MPa]: 65,000 [450]
- Yield strength, min, psi [MPa]: 51,000 [350]
- Elongation in 2 in. [50 mm], min, %: 20

- Reduction of area, min, %: 50

The studs are recognized in ICC-ES evaluation report [ESR-1170](#) and may have a galvanized coating conforming to ASTM A123 and ASTM A153. Galvanization is applied after welding has been completed.

**3.2.2 Base Rails:** The base rails are produced from ASTM A36 / ASTM A529 steel plates and must conform to the following physical and mechanical requirements in accordance with the prescribed values in Table 2 of ASTM A1044:

- Tensile strength, min, psi [MPa]: 65,000 [450]
- Yield strength, min, psi [MPa]: 44,000 [300]
- Elongation in 8 in. [200 mm], min, %: 20

**3.3 Stud Welding:** The CCL Sheartrack® assemblies are factory-welded by CCL to the flat steel base rails using certified welding equipment in accordance with procedures recommended by the AWS. All welding complies with AWS D1.1 / D1.1M requirements.

**4.0 DESIGN AND INSTALLATION**

**4.1 Design:**

**4.1.1 General:** Structural design and installation of CCL Sheartrack® assemblies used as punching shear reinforcement in reinforced concrete slabs must comply with the applicable provisions of ACI 318-14 for the 2018 and 2015 IBC.

**4.1.2 Design Considerations:** The registered design professional must determine and specify the following items, based on design requirements in this report:

- a. The number of studs per rail.
- b. Stud spacing (S).
- c. Sheartrack® assembly overall height (OAH), which must comply with Section 8.7.7.1.1 of ACI 318-14.
- d. Stud shank diameter.
- e. Distance between column face and first line of studs (S<sub>o</sub>).
- f. Base rail plate length (OAL).
- g. Arrangement of Sheartrack® assemblies at columns which must comply with Section 8.7.7.1.2 of ACI 318-14.

**4.1.3 Earthquake Loads:** Sheartrack® reinforcement may be used at slab-to-column connections of structures where a flat concrete slab is used together with primary seismic force-resisting systems in Seismic Categories C, D, E and

F, such as concrete shear walls, under the following conditions:

**4.1.3.1 General:** Lateral force-resisting elements of the structure are designed using the IBC.

**4.1.3.2 Shear Strength:** The nominal shear strength provided by the concrete in the presence of the shear studs referenced in Section 22.6.6.1 of ACI 318-14 must be revised as follows:

$$V_c = 1.5\lambda\sqrt{f'_c}b_o d$$

This revision requires revisions to the nominal shear strength,  $V_n$ , and the maximum shear stress,  $v_n$ .

Two-way slabs without beams designated as part of the seismic force-resisting system, must comply with the provisions in Section 18.4.5.8 of ACI 318-14, except that  $V_c$  must be limited as set forth in Section 4.1.3.2 of this report.

Two-way slabs without beams, which are not designated as part of the seismic force-resisting system, must comply with the provisions in Section 18.14.5.1 of ACI 318-14, except that  $V_c$  must be limited as set forth in Section 4.1.3.2 of this report and the design story drift ratio specified in Section 18.14.5.1 of ACI 318-14 must not exceed the drift ratio referenced in Table 12.12-1 of ASCE/SEI 7.

#### 4.2 Installation:

Installation of the CCL Sheartrack® assemblies must comply with the applicable provisions of the 2018 and 2015 IBC and the approved engineering plans. The CCL Sheartrack® assemblies must be positioned correctly around columns, openings and edges and set in accordance with the IBC and the approved engineering plans and details. Concrete cover must comply with ACI 318-14 Section 20.6.1.3.5. See Figure 1 for typical installation details. Chairs must be positioned a minimum of 2 inches (50.8 mm) from the rail ends or as shown on the approved design details and drawings. Spacer chairs must be securely fastened to formwork to avoid movement during pouring of concrete. CCL Sheartrack® assembly rails must be fastened with wire ties with at least one chair to the rail or one stud to the reinforcing bar to prevent sliding within the chairs.

#### 4.3 Special Inspection:

Special inspection of CCL Sheartrack® assemblies and installation at the jobsite must comply with Section 1705.3 for the 2018 and 2015 IBC. The special inspector is responsible for verifying identification of the CCL Sheartrack® assemblies per Section 7.0 of this report, along with condition, positioning, clearances, and concrete cover to ensure the assemblies comply with the approved design details and drawings and all applicable codes.

### 5.0 CONDITIONS OF USE

The CCL Sheartrack® assemblies described in this report comply with, or are suitable alternatives to what is specified in, those codes listed in Section 1.0 of this report, subject to the following conditions:

- 5.1 The CCL Sheartrack® assemblies must be designed, manufactured, and installed in accordance with this report and the approved engineering plans. In the event of a conflict between this report and the approved engineering plans, the more restrictive governs.
- 5.2 The CCL Sheartrack® assemblies must be stored on the jobsite so as to prevent physical damage and to minimize effects of corrosion. The CCL Sheartrack® assemblies must be free from mud, oil, excessive rust or other non-metallic coatings that decrease bond.

5.3 Design details and structural drawings must be in compliance with the design requirements of Section 4.1 of this report and must be approved by the code official. The calculations and design details and drawings must be prepared by a registered design professional when required by the statutes of the jurisdiction in which the project is to be built.

5.4 Special inspections must be provided in accordance with Section 4.3 of this report.

5.5 The CCL Sheartrack® assemblies are manufactured at the CCL facility in Jessup, Maryland, under a quality-control program with third-party inspections by ICC-ES.

### 6.0 EVIDENCE SUBMITTED

Data in accordance with the ICC-ES Acceptance Criteria for Headed Shear Stud Reinforcement Assemblies for Concrete Slabs and Footings (AC395), dated June 2017 (editorially revised November 2017).

### 7.0 IDENTIFICATION

7.1 The CCL Sheartrack® assemblies are identified on the packaging with part designation, manufacturer's name (CCL), address, logo, required color coding indicating base rail length, overall height, stud diameter, number of studs per rail and rail quantity, and the evaluation report number (ESR-5011).

7.2 The report holder's contact information is the following:

**CCL**  
**8296 SHERWICK COURT**  
**JESSUP, MARYLAND 20794**  
**(301) 490-8427**

### 8.0 OTHER CODES

#### 8.1 Scope:

In addition to the 2018 and 2015 IBC, the products described in this report were evaluated for compliance with the requirements of the following codes:

- 2012, 2009 and 2006 *International Building Code*® (IBC)

#### 8.2 Uses:

See Section 2.0.

#### 8.3 Description:

See Section 3.0.

#### 8.4 Design and Installation:

##### 8.4.1 Design:

- **General:** Structural design and installation of CCL Sheartrack® used as punching shear reinforcement in reinforced concrete slabs must comply with the applicable provisions of ACI 318-11 for the 2012 IBC or ACI 318-08 for the 2009 IBC, as applicable. Under the 2006 IBC, compliance must be with ACI 318-05 and Sections 3.5.5, 7.7.5 and 11.11.5 of ACI 318-08. The specified yield strength of transverse reinforcement,  $f_{yt}$ , must not exceed the specified yield strength of the shear studs defined in Section 3.2.1.

- **Design Considerations:** The structural design of CCL Sheartrack® must determine and specify the following items, based on design requirements in this report:

- a. Number of studs per rail.
- b. Stud shank diameter.
- c. Base rail length.

- d. Shear rail assembly overall height (OAH), which must comply with Section 11.11.5 of ACI 318-11 (2012 IBC) or -08 (2009 IBC).
- e. Stud spacing (S).
- f. Distance between column face and first peripheral line of studs ( $S_o$ ).
- g. Arrangement of headed shear stud reinforcement, which must comply with Sections 11.11.5.2 and 11.11.5.3 of ACI 318-11 (2012 IBC) or -08 (2009 IBC).

● **Earthquake Loads:** See Section 4.1.3.

- a. **General:** See Section 4.1.3.1.
- b. **Shear Strength:** The nominal shear strength provided by the concrete in the presence of the headed shear stud reinforcement, referenced in Section 11.11.5.1 of ACI 318-11 or -08, must be revised as shown in Section 4.1.3.2.

This revision requires revisions to the nominal shear strength,  $V_n$ , and the maximum shear stress,  $v_n$ .

Two-way slabs without beams designated as part of the seismic-force-resisting system, must comply with the provisions in Section 21.3.6.8 of ACI 318-11 or -08 for 2012 and 2009 IBC, respectively, except that  $V_c$  must be limited as set forth in Section 4.1.3.2.

Two-way slabs without beams, which are not designated as part of the seismic force-resisting system, must comply with the provisions in Section 21.13.6 of ACI 318-11 or -08

for the 2012 and 2009 IBC, respectively, or Section 21.11.5 of ACI 318-05 for the 2006 IBC, as applicable, except that  $V_c$  must be limited as set forth in Section 4.1.3.2 and the design story drift ratio specified in Section 21.13.6 ACI 318-11 or -08 or Section 21.11.5 of ACI 318-05, as applicable, must not exceed the drift ratio referenced in Table 12.12-1 of ASCE/SEI 7.

**8.4.2 Installation:** Installation of the CCL Sheartrack® must comply with the applicable code and the approved engineering plans. The CCL Sheartrack® assemblies must be positioned correctly around columns and set in accordance with the IBC and the approved construction documents. Concrete cover must comply with Section 7.7.5 of ACI 318-11 or -08. See Figure 1 for typical installation details.

**8.4.3 Special Inspection:** See Section 4.3, except for Section 1705.3 of the 2012 IBC and IBC Section 1704.4 for the 2009 and 2006 IBC.

**8.5 Conditions of Use:**

See Section 5.0.

**8.6 Evidence Submitted:**

See Section 6.0.

**8.7 Identification:**

See Section 7.0

**TABLE 1—CCL SHEARTRACK® STUD MINIMUM DIMENSIONS**

SHANK DIAMETER, D [in. (mm)]	HEAD DIAMETER, H [in.(mm)]	H/D RATIO	SHANK AREA, S <sub>A</sub> [in. <sup>2</sup> (mm <sup>2</sup> )]	HEAD AREA, H <sub>A</sub> [in. <sup>2</sup> (mm <sup>2</sup> )]	H <sub>A</sub> /S <sub>A</sub> RATIO	HEAD THICKNESS, T [in. (mm)]
3/8 (9.5)	1.19 (30.1)	3.17	0.110 (71)	1.112 (712)	10.1	0.24 (6.1)
1/2 (12.7)	1.58 (40.2)	3.16	0.196 (127)	1.961 (1269)	10.0	0.33 (8.4)
5/8 (15.9)	1.98 (50.2)	3.17	0.307 (199)	3.079 (1979)	10.0	0.40 (10.2)
3/4 (19.1)	2.37 (60.2)	3.16	0.442 (287)	4.412 (2846)	10.0	0.47 (12.0)

**TABLE 2—BASE RAIL MINIMUM DIMENSIONS**

STUD SHANK DIAMETER, D [in. (mm)]	STEEL RAIL WIDTH, W [in. (mm)]	STEEL RAIL THICKNESS [in. (mm)]	STEEL RAIL LENGTH
3/8 (9.5)	1.25 (31.8)	0.25 (6.4)	Determined by the registered design professional
1/2 (12.7)	1.25 (31.8)	0.25 (6.4)	
5/8 (15.9)	1.75 (44.5)	0.375 (9.5)	
3/4 (19.1)	2.00 (50.8)	0.375 (9.5)	

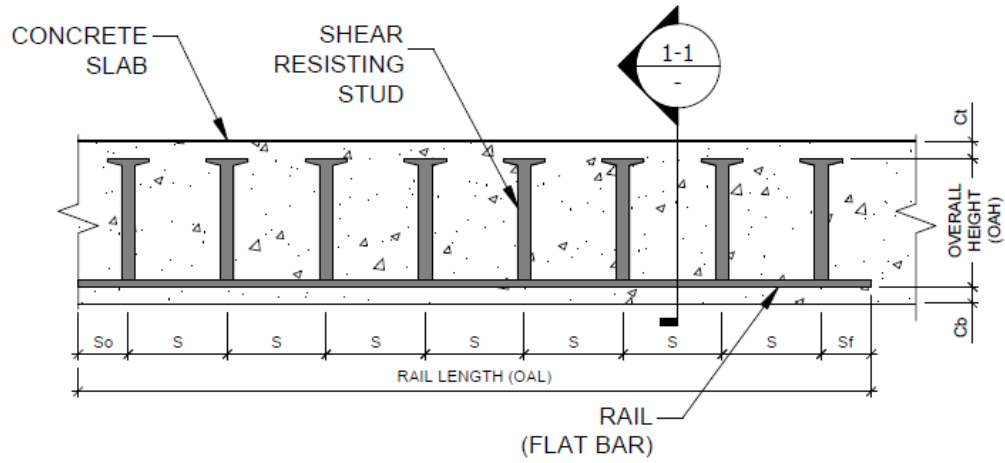
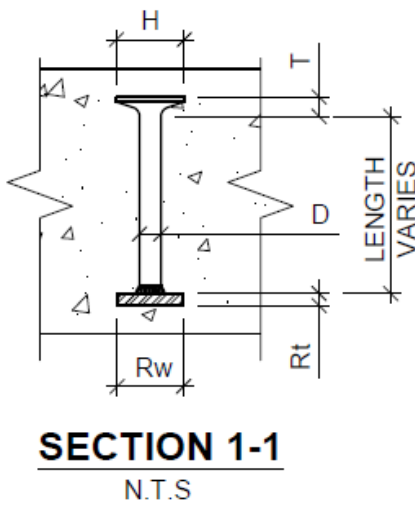

FIGURE 1—CCL SHEARTRACK® ASSEMBLY DETAILS



NOTATIONS USED FOR CCL SHEARTRACK DETAILS	
So	SPACING TO FIRST STUD FROM FACE OF SUPPORT ELEMENT
S	SPACING BETWEEN STUDS
Sf	SPACING TO END OF RAIL PLATE FROM LAST STUD
OAL	OVERALL RAIL LENGTH
OAH	OVERALL HEIGHT FROM BOTTOM OF RAIL TO TOP OF STUD HEAD
D	STUD SHANK DIAMETER
H	STUD HEAD DIAMETER
T	STUD HEAD THICKNESS
Rw	WIDTH OF RAIL
Rt	THICKNESS OF RAIL
Ct	CLEAR COVER AT TOP OF SHEARTRACK
Cb	CLEAR COVER AT BOTTOM OF SHEARTRACK

FIGURE 2—DIMENSIONAL DETAILS